



Electromechanical Level Measuring System



www.fine-tek.com



PRODUCT INTRODUCTION

WORKING PRINCIPLE

FineTek's Electro-Mechanical Level Measuring System (EE300 series) consists of plumb, cable wire, measuring pulley, position sensor, and control board to measure the material level. It senses the weight status and count the cable wire length from the device to the level of material. The EE series equips with robust position sensor to calculate the numbers of rotating circles of pulley, which can be operated in harsh environment. Moreover, it can connect with FineTek's material measurement system (MMS) to build an monitoring control system, save the production cost.

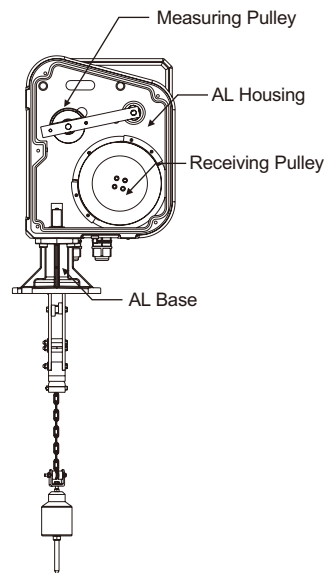

Rear View: Wiring Mechanism

APPLICATION

- The result of measurement is not affected by environmental factors as sound waves, dust, static electricity, humidity and dielectric etc. Can be widely applied for applications in mining, cement, petrochemical, feeding and power plants.
- Suitable for different variety of materials as powder, pellet, liquid, and also good for open tanks or sealed tank with no inner pressure inside.
- Working perfectly with software of material management system (MMS), accurately monitoring and managing the level of materials inside the tank.
- It features multifunction in on, needn't extra controlling box, connecting to panel for a immediate usage is available.

FEATURES

- Measurement immune from the interference of environment such as sound waves, dust, capacitance, or temperature change.
- User-friendly in touch buttons with microprocessor-based calculation design.
- High level and low level alarm. (3A/250Vac, SPDTx2)
- EE300 is equipped with LCD Dot matrix: 8x2,
- Analog output: 4-20mA dc.
- Pulse output:
 - Transistor output NPN/PNP(10mm/pulse)
 - Relay output 3A/250Vac(100mm/pulse)
- Cable Break Alarm: System will detect cable broken during measuring. (only EE400)
- Plumb Buried Protection: System can sense and stop the measurement as the plumb hit by materials and retrieve the wire to prevent the plumb being buried.
- Plumb Buried Alarm: System will detect plumb buried by the medium.
- Four Start Modes: auto start, manual start, intelligent start, and external triggered start.
- Intelligent Start: Measuring interval is inverse proportional to medium level.
- Auto Return Setup: Prevent sensing weight from buried or sliding into the tank pivot and avoid damage facility equipment while tank is empty.
- Material Fill-Up Protection: Reduce the possibility of plumb being buried.
- Measuring range of 30m (Standard), Max.45m is available for EE300.
- RS485 MODBUS communication protocol.
- Various selections of weights for different requirements.
- Freeze Prevention Capability: being able to work normally in cold temperature.

Product Testing Standards

- Protection IP Rating: IP66(IEC60947-2)
- IEC Standards for Withstand Voltage: IEC60947-2
- IEC Standards for Insulation resistance: IEC60092-504
- IEC Standards for changes in power supply: IEC60092-504
- IEC Standards for power supply failure: IEC60092-504

SPECIFICATION

No.	Category	EE300
1	Power supply	88~264Vac 50/60Hz
2	Auccuracy	1. Transistor output: NPN / PNP (10mm/pulse) 2. Relay output: 3A/250Vac (100mm/pulse)
3	Analog output	0/4-20mA \pm 1%
4	Ambient temperature	-35°C~60°C
5	Operating temperature	-35°C~80°C
6	Measuring range	max.30m(option:30~45m)
7	Measuring speed	Avg. 0.23m/s
8	Protection rating	IP66
9	Body material	Aluminum
10	Display	LCD (Dot matrix , 8 X 2)
11	Status LED	LED Display: 1.Lock (Red) On (Fill-Up Protection) 2.RUN (Yellow) On 3.Buried (Red) Blink for 1 second 4.Break (Red) Blink for 2 seconds 5.Auto (Blue) On 6.High Alarm (Red) On 7.Low Alarm (Red) On
12	Relay output	SPDT 3A/250Vac X 3 1. HI Alarm 2. LO Alarm 3. Buried: Blink for 1 second when alarm triggers Break: Blink for 2 seconds when alarm triggers Lock: LED on when alarm triggers
13	Anti-Dew heater	Start heating <16°C (freeze prevention, prevent dew) 110/220Vac max. PF 96.8W
14	Cable break detection	Yes
15	Plumb buried detection	Yes
16	Auto measuring mode	Yes (0.1~99h)

SPECIFICATION

No.	Category	EE300	
17	Activating from outside	Yes	
18	Motor limited current protection	Yes	
19	Malfunction diagnosis display	Yes	
20	Material fill up protection	Yes	
21	Communication protocol (RS485)	Yes	Frame C8N1.C8N2.C801.C8E1.C7N2.C701.C7E1.C702.C7E2.
			Baudrate 1200.2400.4800.9600.11520.14400.19200.28800.57600
22	Intelligent start	Yes (Measuring interval is inverse proportional to medium level)	
23	Cable wire	φ1.2mm	

EE300 SKETCH & DRAWING/ DIMENSION

Sketch & Drawing

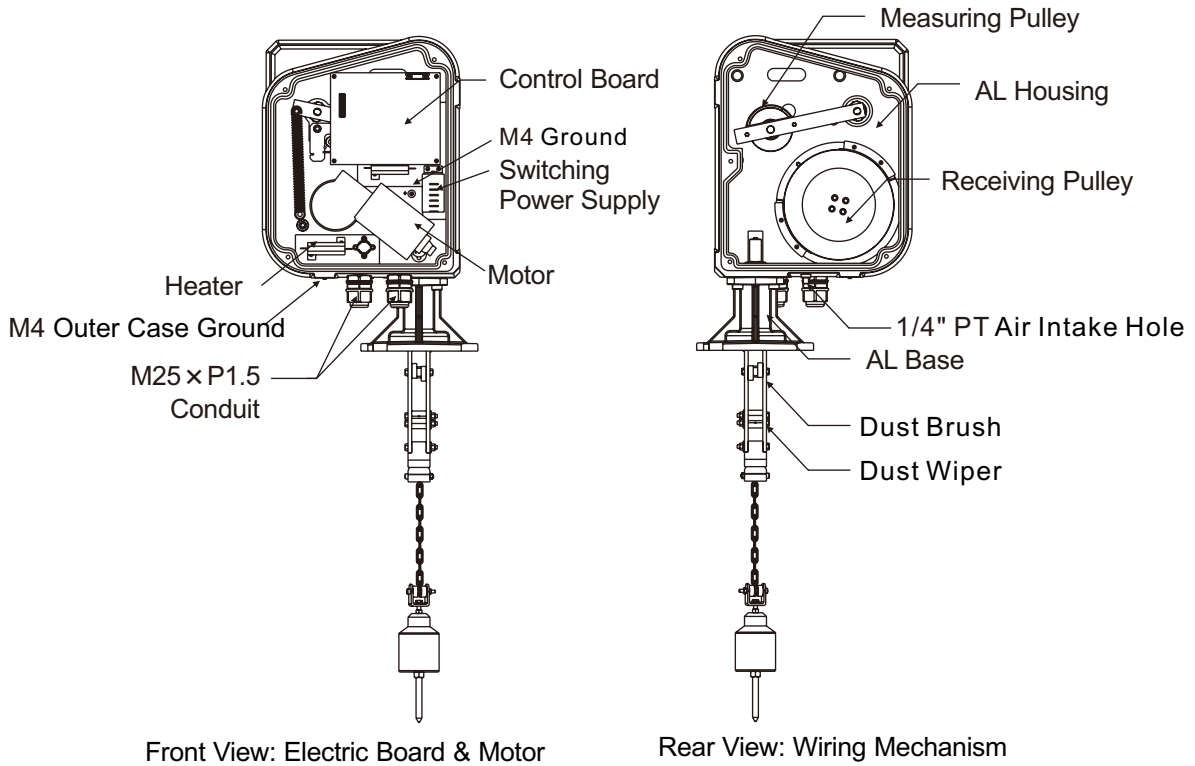

Dimension

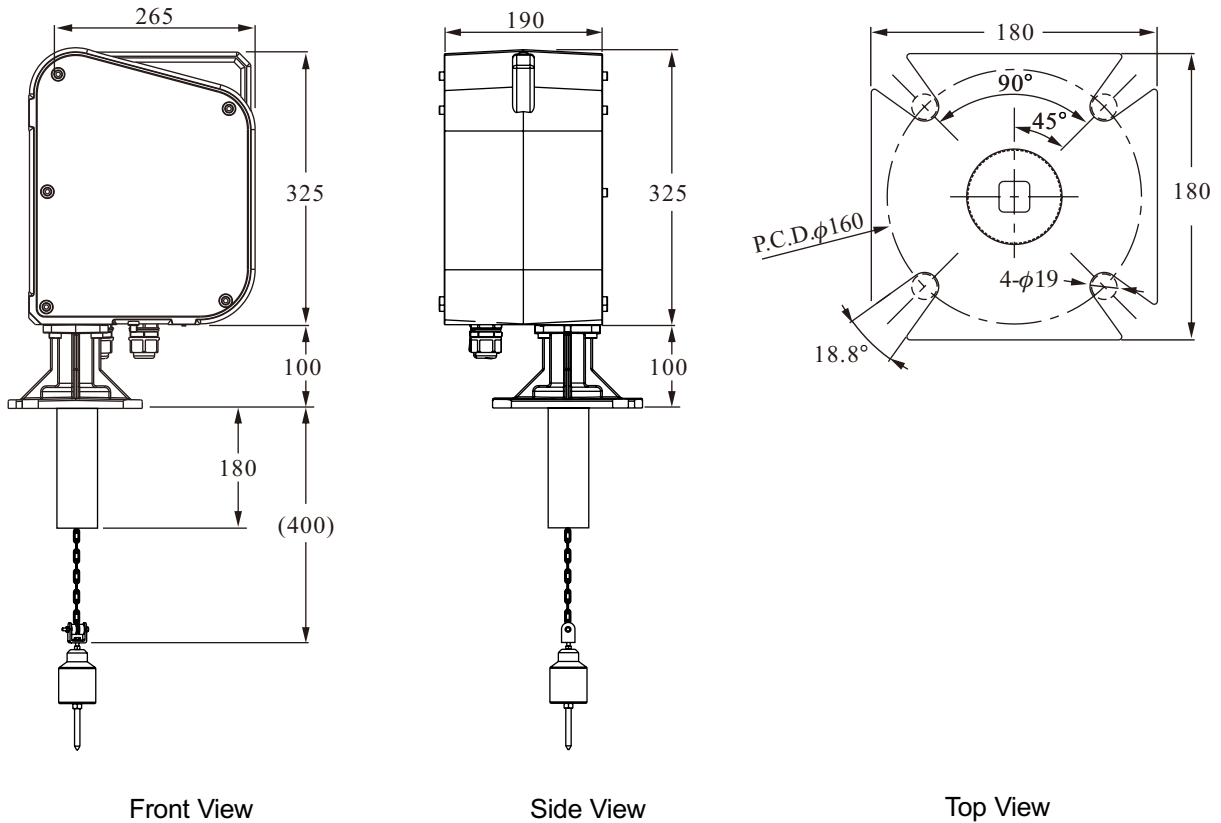

EE300 TERMINAL WIRING DIAGRAM/ DESCRIPTION OF PANEL

EE300 Terminal Wiring Diagram

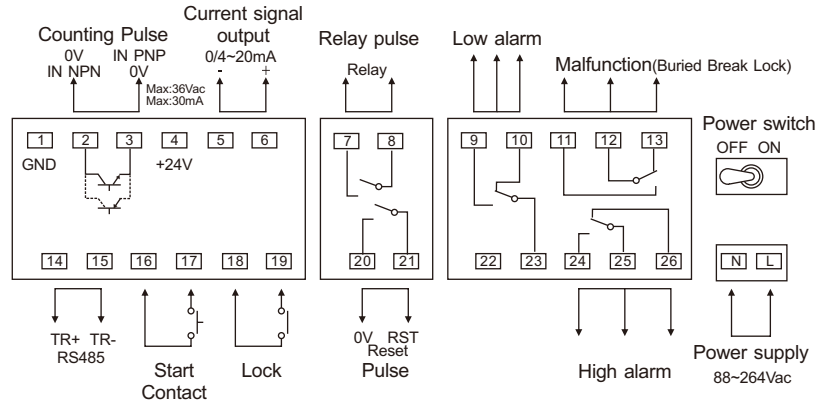

Ee300 Panel Diagram

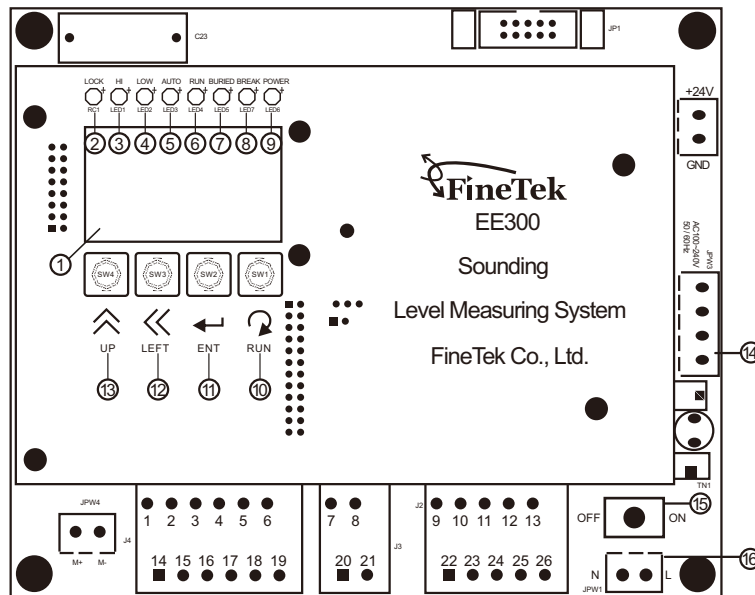

- ① Characteristic LCD (Dot matrix , 8 × 2), provides the status, level command and error message.
- ② The "Lock" light on as the material filling and the measurement will be prohibited.
- ③ High Level Alarm Indicator (HI), light on if the material level exceeds the preset high threshold.
- ④ Low Level Alarm Indicator (LOW), light on if the material level is below the preset low threshold.
- ⑤ Auto Start Indicator (AUTO), light on to indicate EE is in automatic operation mode.
- ⑥ Start Indicator (RUN), light on if the EE is in measuring period, and it turns light off status while the measurement completed.
- ⑦ Weight Head Buried (BURIED), blink light on /off in 1 sec period to warn operator, the LCD will show BURIED message.
- ⑧ Cable Break Indicator (BREAK), blink light on /off in 2 sec period to warn operator, the LCD will showBREAK message.
- ⑨ Power Indicator (POWER), "Light On" for power on and "Light Off" to indicate power off.
- ⑩ "Start", start the operation.
- ⑪ "Enter", acts as "confirm button" at setting mode and as "page select button" at menu mode.
- ⑫ "Shift", acts as "decimal shift" while enter digits and as "enter button" at menu mode.
- ⑬ "UP", acts as "Increment button" while enter digits and as "Escape button" at menu mode.
- ⑭ Terminal (H1.H2) for heater.
- ⑮ Power switch: to turn on, turn off power
- ⑯ Power connector (L.N), accepts the power of 88~264Vac, 50/60Hz ◦



- Please use 0.75mm² multi-core cable(soft cable), prevent using signal core or 7 cores cable to damage the PCB. Power supply cable should be separated from signal cable, should use isolated cable for signal output.



- Un-shielded length of wire is not too long to prevent any short circuit. The un-shielded part must be with soldering or isolated terminal to prevent any potential danger.
- The wiring connection must be correct. Any mistakes on wiring may cause a critical damage to system.
- Power Switch: If necessary, the power can be switched to be off as in maintenance and repair.

EE300 Terminal Diagram

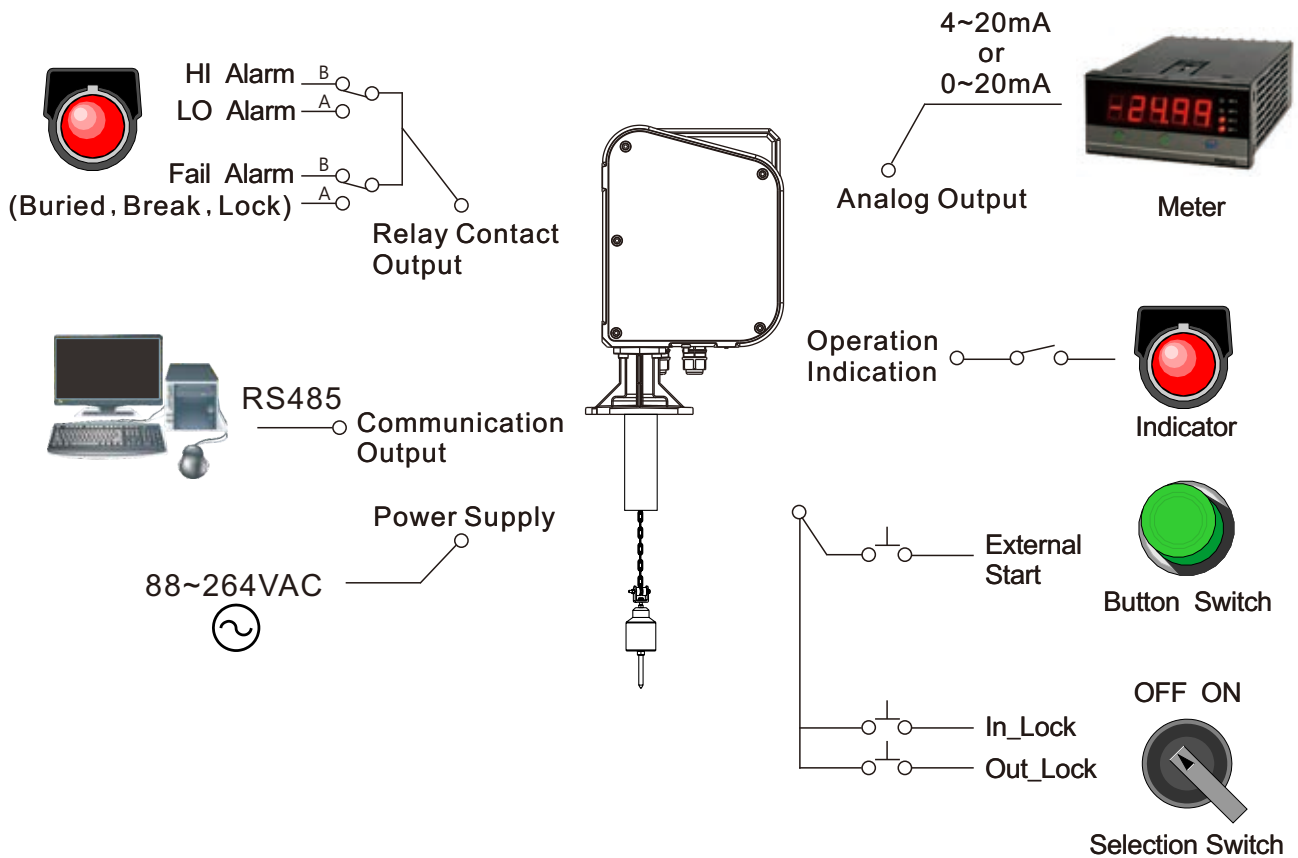

PROGRAMMING GUIDE

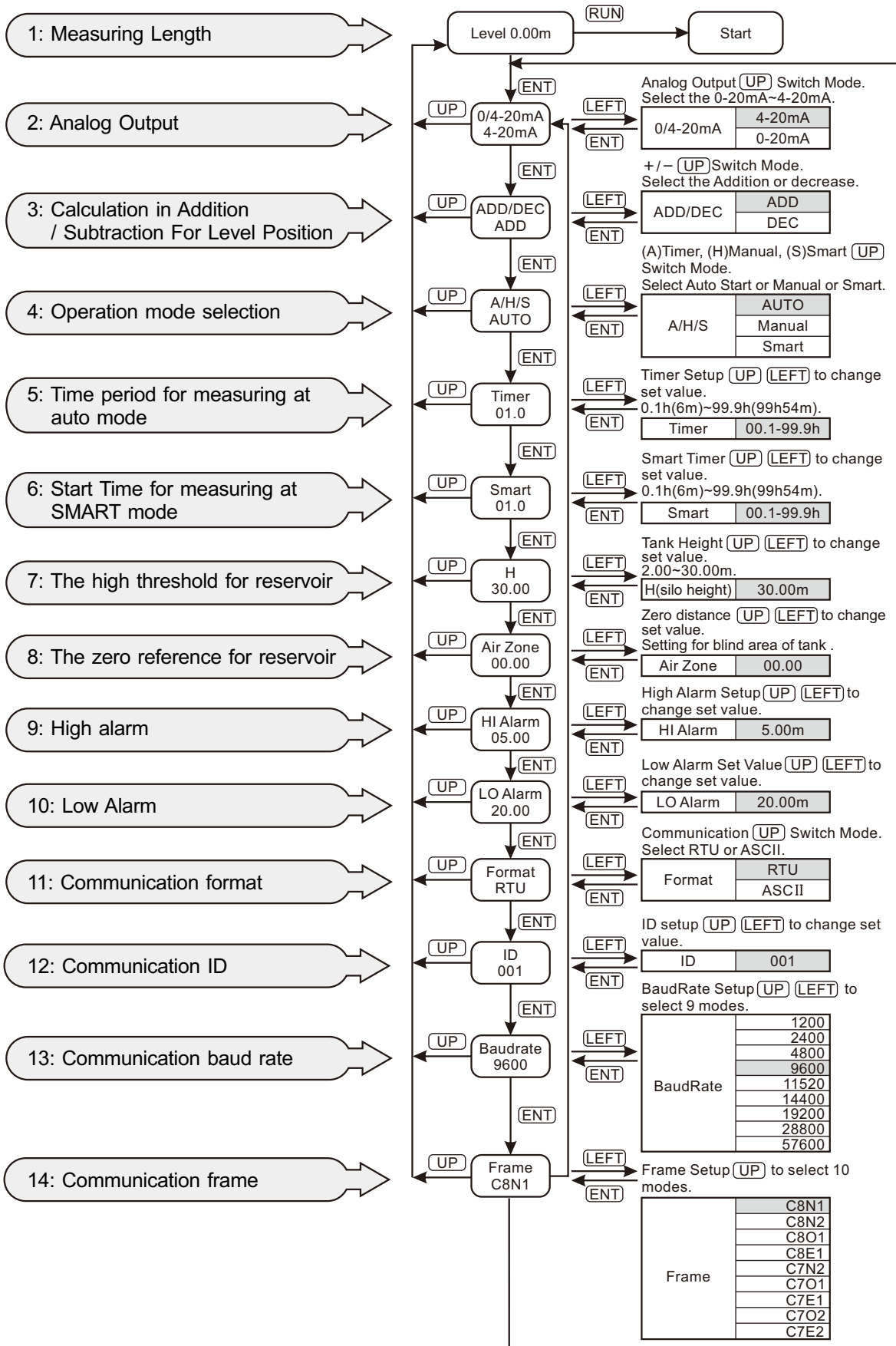

SETTING PROCEDURE

Caution

1. Don't start the measurement when the silo is empty and height of silo is unknown. It will possibly lead to the plumb falling into the silo outlet and getting stuck and damaged.
2. Be sure the measuring level must be higher than bottom of silo and avoid any possibility of being stuck by conveyer, ladders, and any mechanisms, suggesting the measuring level is at least 1 meter higher than silo outlet/ conveyer.
3. Materials filling conveyer must connect with filling up protection switch so that it will prevent the damage occurred by plumb got hit or buried.
4. It's necessary to consider 0.6 meter as blind area for measuring range in case the plumb got stuck and can't be retrieved.

Setting Procedure

K Tank Height:

distance between connecting flange to tank outlet

S Blind Distance:

distance from connecting flange to the tip of the weight

Z Safety Distance:

To avoid obstacle and prevent weight sliding into the outlet.

H Measuring Height:

Full measuring range from drop and return with full pulse signal record.

A Air Zone(deadband):

Variation of tank capacity and real medium level. Default setting is 0.

H Effective measuring distance:

distance will change according to A value and corresponds to 0/4~20mA output signal.

Hi Alarm: High level alarm setup.

Lo Alarm: Low level alarm setup.

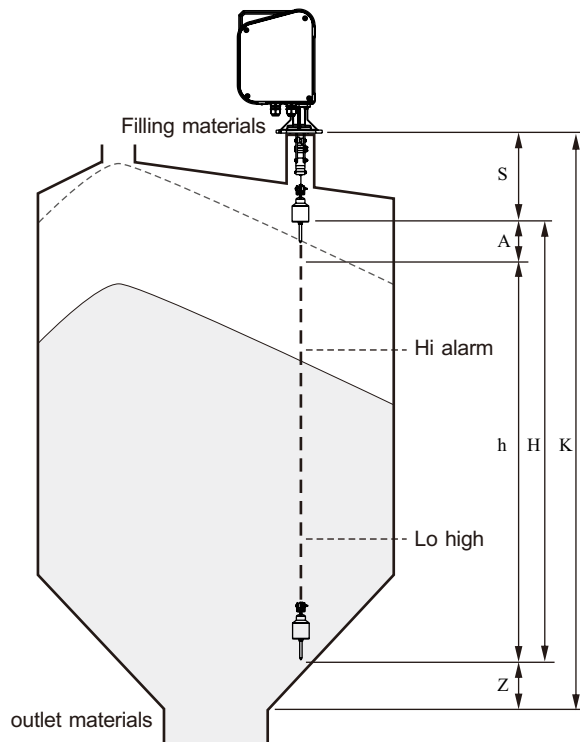

Example

Tank height $K=25.00$ m, Blind distance $S=0.4$, Safety distance $Z=0.6$, Air Zone(deadband) $A=1$ m,

Hi alarm 80%, Low alarm 20%,

In Smart Mode, please try to calculate and get the values for H(measuring range), A(starting position of effective measuring distance), Hi alarm position, Low alarm position.

1. $H = K - (S + Z) \rightarrow 25 - (0.4 + 0.6) = 24$, FULL measuring distance will be 24.0m

2. $A=1$ m \rightarrow Effective measuring distance $h=23$ m

3. Hi Alarm = $h \times 80\% \rightarrow 23 \times 0.8 = 18.4$, hi alarm position: 18.4m

4. Lo Alarm = $h \times 20\% \rightarrow 23 \times 0.2 = 4.6$, low alarm position: 4.6m

INSTALLATION

Installation Position

- Installation position should be away from the inlet or outlet of silo at least 1.2 m, and prevent the damage occurred by plumb got hit or buried.
- Reservoir or tank equipped with observation window is suggested; it will be beneficial for maintenance in future. The installation location should be away from the ladder, frame or any protrusion. The minimum distance between the EE300 center and tank wall should be 1m or more.
- Must be located away from the inlets flow direction to avoid the cable and hammer being damaged by material or disconnected or buried.
- The optimal position is at the average depth of measured material, it will generally locate in the middle of the peak and bottom (the angle of repose after filling process), indicates below.

Installation Instruction

- Please ensure that the flange is horizontal positioned and the installation is vertical. The movement of sensing weigh must be vertical and aligning with central of flange so that it can prevent incorrect movement and wear on wire.
- Welding a steel tube on silo roof is necessary if the silo roof is not in horizontal shape. In order to install horizontally, the diameter of welded steel tube must be more than 4" and the length is as short as better. It is suggested to put a gasket between two flanges.
- Please make sure the housing is air tight. The aluminum cover for housing must be screwed tight.

Caution

- The position and method of inlet condition installation:
 - 1.Direct filling: Please install at either side of inlet.
 - 2.Vortex filling: Please install at left side of inlet as in clockwise direction or at right side of inlet as in counter-clockwise direction.
 - 3.Sprinkle filling: Please install farthest at the opposite to inlet to avoid impact by filling.
- During installation, user should carefully check the cable wire is wound up well in pulley set and not folded, broken or squeezed.
- The cable wire should put on the hole of weight head connect and be secured indeed by screwdriver.
- Firmly secure the screws to fix the front cover and body, otherwise the dust or powder will permeate into the electric board.
- The installation hole must be larger than diameter 104 mm.

Wiring Instruction

- FineTek suggests 0.75mm² non-twist multiple-cores isolated electric wire to connect with the terminal block.
- The power line should be separated from the signal lines. It should leave a flexible length of electric wire to avoid pull and drag the electric board.
- The length of wire stripping should be proper to prevent circuit short, and should be well welded and connected by terminal block well.
- Wiring should be clearly identified and in correct connect.

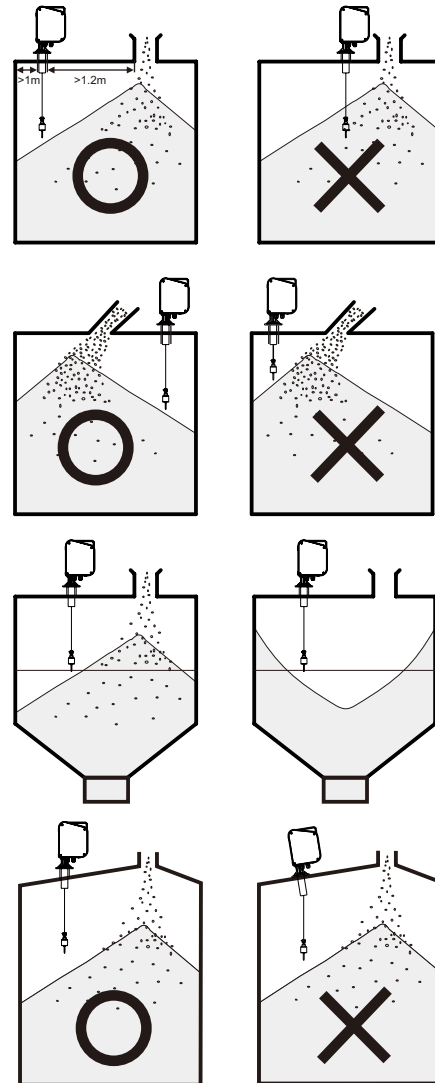

ORDER INFORMATION

Please provide the following parameters and equipment needs when inquiring

1. The name of the material to be measured: _____
2. Material morphology: powder 、 granular 、 massive 、 fluid
3. Granularity: _____
4. Specific gravity: _____
5. Pressure: normal pressure
 Transient Pressure: _____ kg / cm²
 sustained pressure : _____ kg / cm²
6. Tank -temperature: _____ °C
7. Humidity: _____%
8. Supply Voltage: AC : _____V 、 DC : _____V
9. Installation size: Screw thread specifications flange specifications
10. RCU controller: required not required
11. Control box not required
 required , need functional description: _____
12. Other instrumentation needs: not required
 required , specifications description: _____
13. Tank height (K): _____ m
14. Extension tube height (B): _____ m
15. Measuring span (H): _____ m

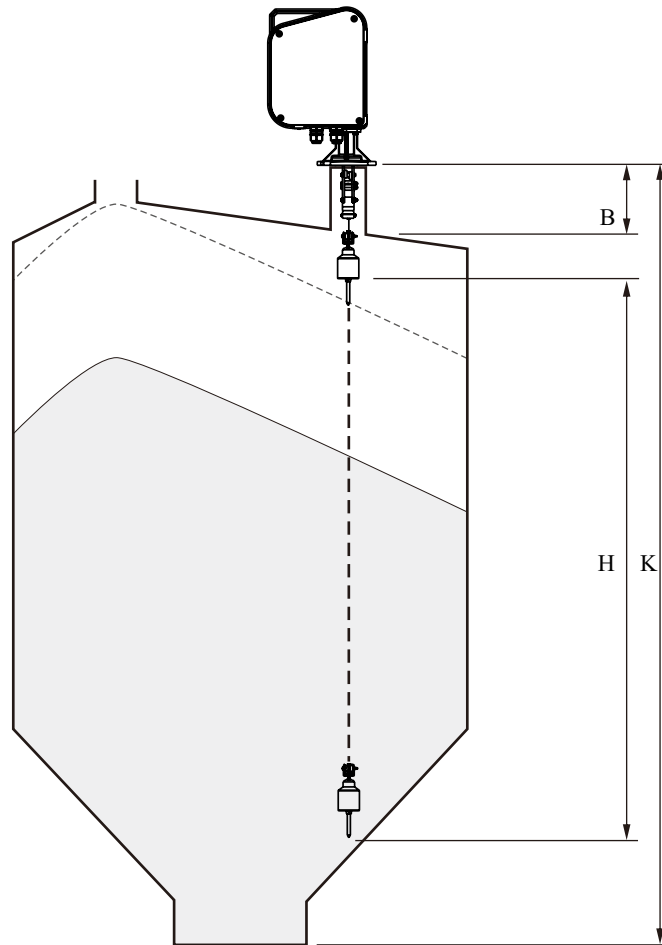

ORDER INFORMATION

EE300 - 1 - -

CONNECTION

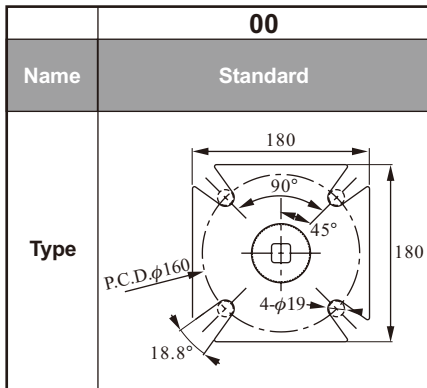

※ Flanges For Standard Model :

4"x5kg/cm²、4"x10kg/cm²、4"x16kg/cm²、4"x20kg/cm²、4"x150Lbs
 DN100 PN6、DN100 PN10、DN100 PN16、DN100 PN25、DN100 PN40

SENSING WEIGHT TYPE

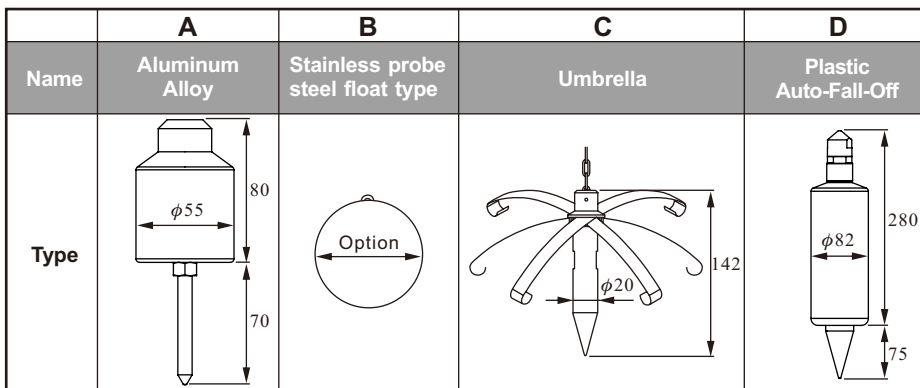

※ Custom made is available for sensing weight

MEASURING RANGE (m)

02:2m(min.)

30:30m(max.)

※ Custom made Length 31~45m